

AD Notes

- Available in 18 and 16 gauge
- Fire label is extra
- For use with #8 x 2 1/2" Drywall type mounting screws (extra).
- Option: use #8 self-tapping masonry screws (by others)
- For use with GJ64 grommet type bumpers (extra).
- KD mitre tabs included
- Surface closer reinforcing is extra
- For use with parallel arm closer reinforcing (extra)
- All dimensions are nominal
- Any item not listed is considered extra

Embossed Fire Label

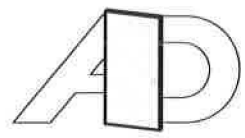
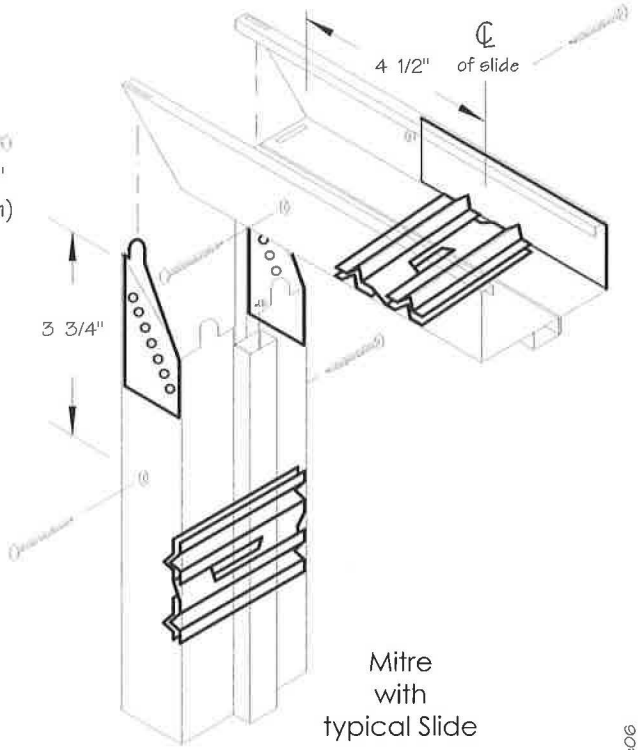
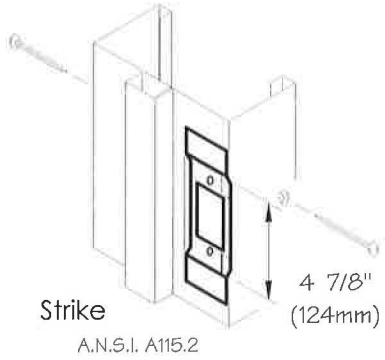
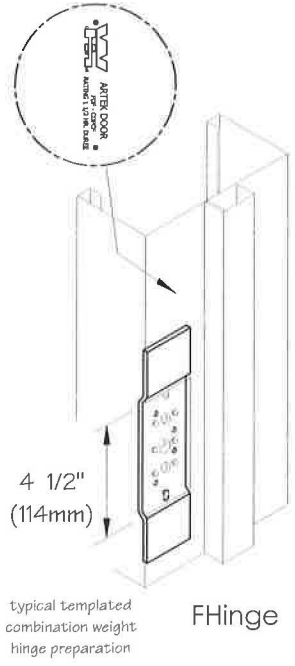

Elevation and Details for 6'8 and 7'0 Expandable Pressed Steel Frame